

## 10' Spee-D Channel with Galvanized Metal Grate

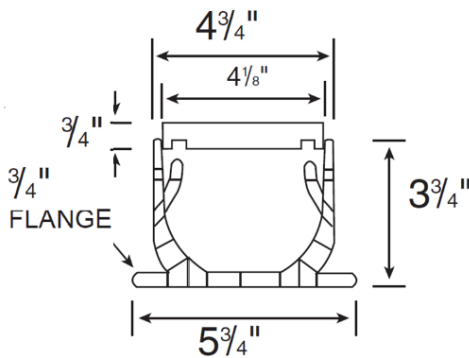
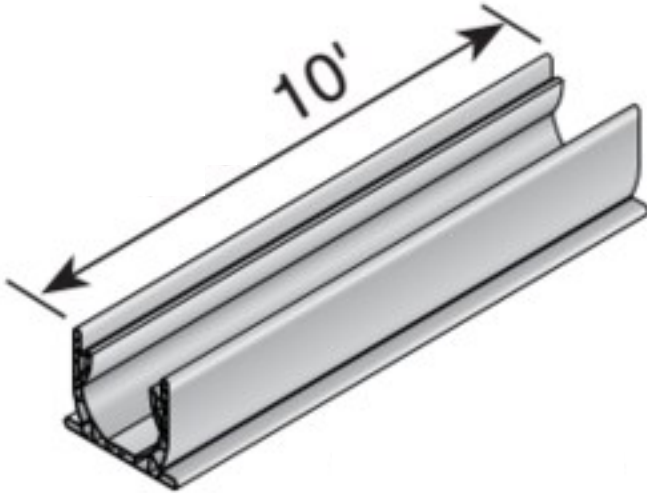

### SPECIFICATION:

SPEE-D CHANNEL DRAIN - 4-3/4" OUTER WIDTH, 4-1/8" INNER WIDTH, 10 FT LONG NEUTRAL CHANNELS

THE CHANNEL IS MANUFACTURED FROM PVC, MADE IN THE U.S.A. AND CONNECTED WITH COUPLINGS (PART #248-SOLD SEPARATELY). THE #254 GRATES ARE MANUFACTURED FROM GALVANIZED STEEL AND PREFASTENED TO THE CHANNEL WITH THE REQUIRED #229 SCREWS. THE CHANNEL DRAIN SYSTEM CAN BE INSTALLED FLAT OR ALIGNED WITH A SLOPED GRADE AT THE SURFACE TO INTERCEPT SHEET FLOW DRAINAGE AND CONVEY IT TO AN APPROPRIATE OUTLET. ADA COMPLIANT.

OTHER ACCESSORIES SUCH AS OUTLETS CAN BE CONFIGURED AS BOTTOM OR END OUTLETS (SEE ACCESSORIES PAGE—SOLD SEPARATELY)

**PART #:** 400-10MTL

**CONTAINS:** (1) - #400 CHANNEL (10-FT CHANNEL)  
(5) - 2' #254 GALVANIZED STEEL GRATE  
(20) - #229 SCREWS

**CHANNEL MATERIAL:** PVC

**GRATE MATERIAL:** GALVANIZED STEEL

**COLOR:** CHANNEL GRAY  
GRATE: GALVANIZED STEEL  
(UV INHIBITORS)

**WEIGHT:** 20.5 LBS

**GRATE OPENING:** 0.45" X 2.85"

**OPEN SURFACE AREA:** 15.49 SQ. IN. PER FT.

**FLOW CAPACITY:**

- 47 GPM WITH 0.5" HEAD
- 67 GPM WITH 1" HEAD

**SCREW:** 4 STAINLESS STEEL SCREWS PER GRATE

FH #8 X 1" (PHILIPS FLAT HEAD)



### Class B

- Loads of 61-175 psi.
- Recommended for medium-duty pneumatic tire traffic, autos and light trucks at speeds less than 20 m.p.h.

**Note:** Some installations may require a concrete collar to meet load rating. Loads are based on encasing product in concrete. Product must be installed using NDS instructions.

### ADA Compliance

NDS provides a wide selection of grates that are compliant with the Americans with Disabilities Act. The ADA Accessibility Guidelines For Buildings and Facilities Section 4.5.4 specifies that ground and floor grates "shall have spaces no greater than 1/2 in (13 mm) wide in one direction."

We are pleased to provide grates that comply with these requirements, so that no individual need be limited from accessing the area safely and confidently.

To see if a grate is ADA compliant, please check the description of the product in our NDS Drainage Catalog: products that meet these requirements are marked "ADA compliant."

Like to find out more about ADA compliance and NDS? Send us your question and we'd be happy to help.



Rev 3/04/24

