

Pro-Spec[®] Series – 14 in. X 19 in. TELECOM Box (313BCBT) Box with Marker Disc (313BCBT-M)

APPLICATION

- Protects critical infrastructure in fiber to the home (FTTH) installations
- Provides easy access for service and maintenance

FEATURES

- “TELECOM” marking on cover
- Commercial grade box and cover engineered for heavy-duty use
- Structural support ribs reinforce box for added strength
- Includes bolt to secure cover
- Universal Locking Mechanism (ULM) – patented design
 - Enables various sizes of bolts/screws to secure cover with a size range of 3/8 to 1/2 in. diameter and minimum 2-1/2 in. length
 - Nut is no longer needed but speed nut slot also exists (speed nut not included)
- Available with electronic marker disc (frequency 101.4 kHz) installed on 313BCBT-M

Universal Locking Mechanism



Marker Disc



SPECIFICATIONS

- Box material: HDPE
- Cover material: HDPE
- Box weight: 5.70 lbs.
- Cover weight: 2.61 lbs.
- Total weight: 8.31 lbs.
- Load rating: Pedestrian and lawn care equipment
- Pallet quantity: 72
- Truckload quantity: 4,032

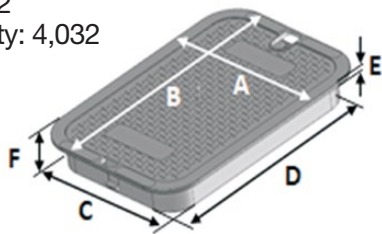

Cover Dimensions (nominal)

Cover Dimensions (nominal)	
A. Top width	11-1/2 in.
B. Top length	16-5/8 in.
C. Bottom width	10-1/8 in.
D. Bottom length	15-1/4 in.
E. Rim thickness	1/4 in.
F. Overall height	2 in.

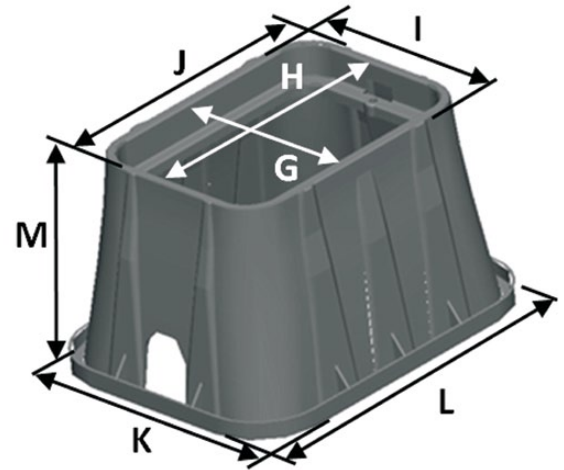

Pipe hole: 2-1/2 in. X 3-1/4 in.

Box Dimensions (nominal)

Box Dimensions (nominal)	
G. Top inside width	10-1/4 in.
H. Top inside length	15-1/4 in.
I. Top outside width	11-5/8 in.
J. Top outside length	16-1/2 in.
Bottom inside width	14 in.
Bottom inside length	19-1/2 in.
K. Bottom outside width	15-3/4 in.
L. Bottom outside length	21-1/8 in.
M. Height	12 in.