



**NDS**®  
We put water in its place

**EZ Roll™**  
**Gravel Pavers**

## Technical Specifications Guide



### Model Numbers

GP4X150  
GP4X150G  
GP4X150R  
GP4X150T



## **3 Product Description**

Design theory

Recommended use

Product features

## **6 Technical Specification**

Compression testing

Fire resistance

Permeability

ADA Compliance

## **9 Contribution to LEED**

## **10 Installation Guidelines**

Pre-installation

Base course details

Staking recommendations

Markers

Site selection and preparation

Paver assembly and installation

Maintenance tips

## **17 Supplemental Documents**

Product guide specification

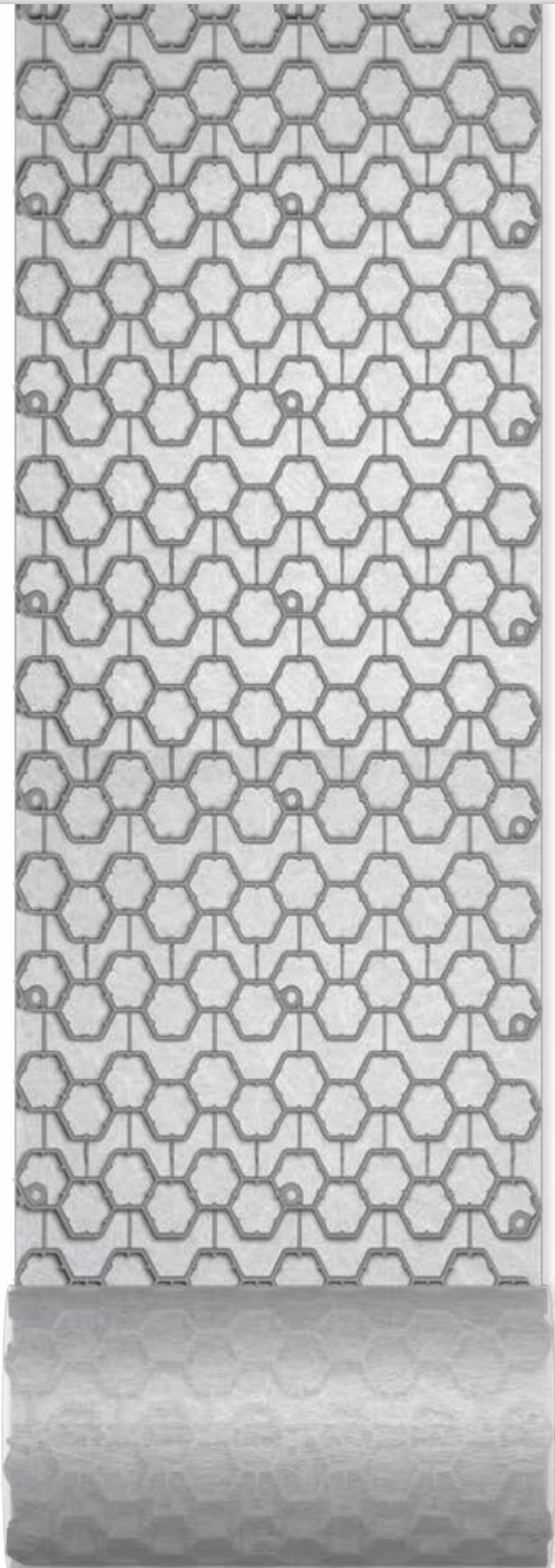

## EZ Roll™ Gravel Pavers

A turf reinforcement, load transferring paving system designed to be placed directly on an engineer specified compacted road base.

This system is designed to transfer vehicle weight directly to the supportive base course and prevent soil compaction. The web of interconnected honeycomb cells provides resistance from vehicular load as well as lateral containment that prevents soil compaction. This system also provides a porous condition that allows rapid absorption of storm water. When properly installed according to the instructions in this guide, EZ Roll™ Gravel Pavers provide a structural surface capable of supporting H-20 loads in a saturated condition. The 1" deep hexagonal cells of the EZ Roll™ Gravel Paver are arranged in a double-row configuration that spans the width of the roll. This configuration reduces the risk of grid displacement from the torsional effects of the turning tires of a stationary vehicle. EZ Roll™ Gravel Pavers have a compressive strength of 57,888 psf in an empty condition and greater than 500,000 psf when filled. The EZ Roll™ Gravel Paver system has been used and accepted across the country for a wide variety of projects including emergency vehicle access purposes.

Additional information, details, and specifications can be found at  
<http://www.ndspro.com/permeable-pavers/Gravel-pavers/ez-roll-gravel-pavers>  
For further technical support or assistance, contact: [techservice@ndspro.com](mailto:techservice@ndspro.com)

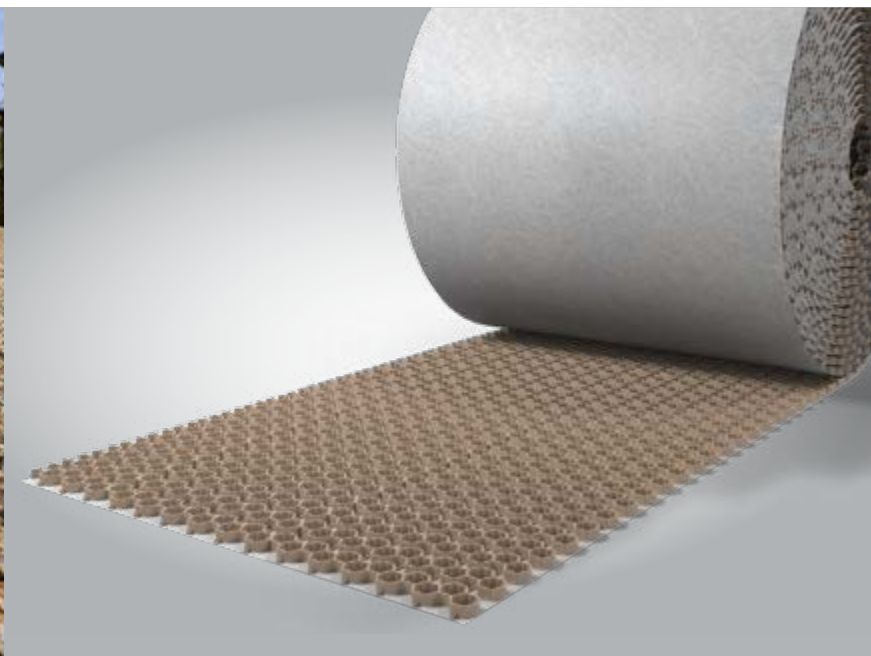

# Product Description

## Design Theory

The EZ Roll™ Gravel Paver comes in pre-assembled rolls, which means it is easy to roll out, decreasing installation time and increasing efficiency.

EZ Roll™ Gravel has been tested for compressive strength at 57,888 psf bare product, meaning that EZ Roll™ does not rely on the fill material for load carrying.

Connections between rows of EZ Roll™ are secure due to unique side-to-side and end-to-end clips that minimize the paver mat movement and separation due to lateral and horizontal pressure. These sturdy locking clips prevent paver displacement or mat failure that could result from traffic load movement or changing ground conditions.

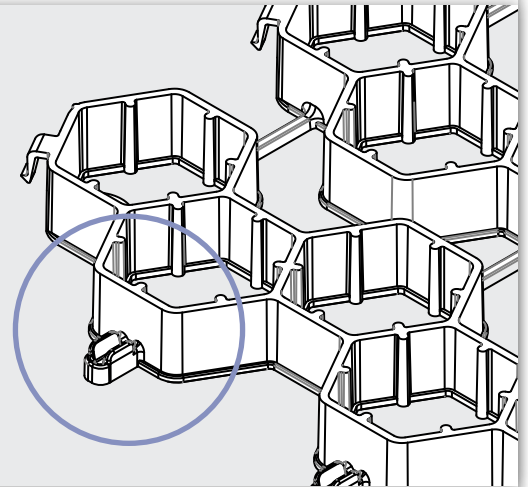

## Recommended Use

### Light Loads:

- Golf Cart Paths
- Jogging Tracks
- Bike Paths
- ATV Paths
- Equestrian Parks
- Trail Reinforcements

### Medium Loads:

- Roadway Shoulders
- Residential Driveways
- Parking Lots
- Overflow Parking Area
- Truck & Cart Wash-Down Areas
- RV and Boat Access

### Heavy Loads/Fire Lane:

- Emergency Vehicle Access Roads
- Service Vehicle Utility Roads
- Equipment Yards

### Non-load Applications:

- Erosion Control on Slopes (staking recommended)
- Erosion Control in Swales (staking recommended)

### Not Recommended for the Following:

- Traffic on slopes exceeding a 10% grade
- To support tread driven vehicles





# Product Description

The EZ Roll™ Gravel Pavers from NDS is the latest and most advanced product of its type on the market. NDS has used its years of experience in the landscaping industry to create a product with all of the most desirable features.

The EZ Roll™ Gravel Paver has a combined series of 72 nested hexagonal cells per paver cell with 24 connecting clips. This unique combination provides superior stability and durability.

## Product Specifications

**Material.** 100% recycled HDPE plastic (50% pre-consumer 50% post-consumer). HDPE is rugged, flexible and ideally suited for outside exposure and longevity. NDS uses UV inhibitors in the polymer structure to prevent breakdown in the strength of the paver.

**Color.** EZ Roll™ Gravel is available in tan, black, brick red, and gray to provide design flexibility.

**Manufacturing.** Manufactured in Lindsay, CA.

**Recyclability.** 100% recyclable. Please recycle whenever possible.

**Paver Size.** Each 24" x 24" panel contains 72, 2¼" nested hexagonal cells. Panels are integrated with crosslinks and clips to form rolls. Part No. EZ4X150 has dimensions of 4' x 150' per roll. Custom size rolls available upon request.

**Weight Per Unit.** 2.31 pounds per 24" x 24" section.

**Paver Details.** The top surface of the hexagonal cell walls is smooth and devoid of notches or grooves. The bottom surface of the paver mat has over 80% open area for increased permeability.

**Assembly Mechanism.** 12 lateral snap locks per panel.

**Chemical Resistance.** EZ Roll™ Pavers have superior chemical resistance and are totally inert.

**Compressive Strength.** 57,888 lbs. (psf.) which is equal to 414 lbs. (psi.) For detailed specs see the Technical Specification part of this Guide.

**Unique Product Features.** EZ Roll™ Pavers feature an easy to install top down locking feature. This locking mechanism allows pavers to be installed quickly and easily.

Empty cells have a compressive strength of

# 57,888 psf

Product ships in large rolls for easy rollout

Easy to connect

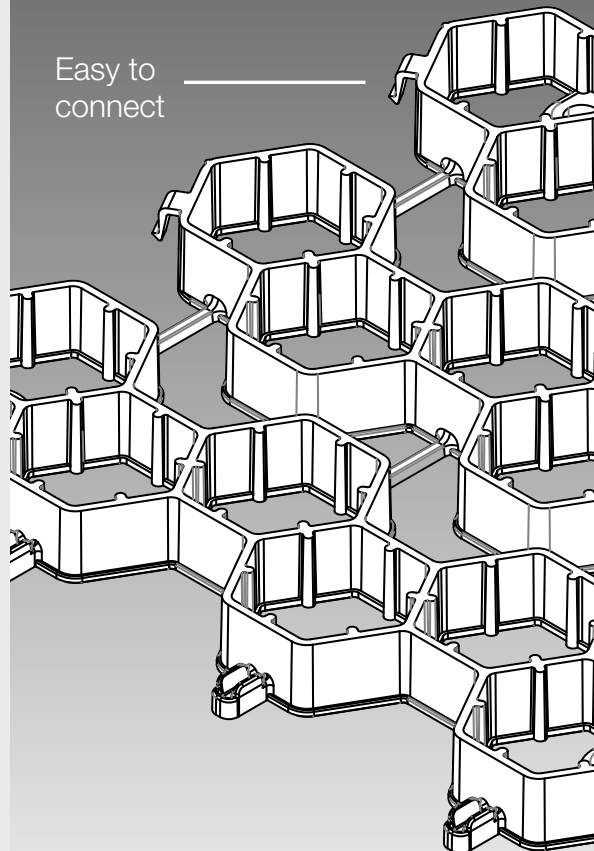

## Testing Methods

EZ Roll™ Gravel Pavers undergo a battery of tests with each production run, as is the process with all products manufactured by NDS.

All the manufacturing tests are conducted within the manufacturing cycle to assure a quality-finished product.

### Fire Resistance

When tested in accordance with ASTM D 1929-96 and DIN 54836-1984, HDPE has an ignition temperature of 350-360°C or 662-680°F. HDPE does not support flame.

### Compression Tests

Compression tests were performed by Smith Emery Laboratories in Los Angeles, CA. Each sample paver was individually placed flat on the fixed 18' x 18' plate of a load testing machine. A load was then applied to the top surface of the paver, through a 12' x 12' steel plate until failure. The ultimate compressive strength of the paver is 57,888 pounds per square foot (bare product without fill material). This is over double that of an H-2O loading specification.

Test Type	Test No.	Loading Plate	Max. Load (lbs.)	Remarks
Unfilled Cell	1	12 x 12	57,888	The wall of the paver cell buckled under pressure
	2		59,000	
Filled with Sand (clean concrete sand)	1	6 x 6	500,000+*	Paver cell was compressed down along with the sand
	2		500,000+*	
Filled with Gravel (concrete pea gravel)	1	6 x 6	500,000+*	Paver cell was compressed down along with the gravel
	2		500,000+*	
Filled with Soil (clay soil)	1	6 x 6	500,000+*	Paver cell crushed
	2		500,000+*	

\*Test maximum limit 500,000 lbs.

## Permeability

EZ Roll™ Gravel Pavers provide a lower runoff coefficient, a prolonged time of concentration, a much higher rate of percolation and a cleaner runoff of storm water than concrete or asphalt.

When used over a rock and sand base with sandy loam soil (CN30), EZ Roll™ will promote a situation unlikely to generate surface runoff in an average rainstorm (less than 6" in 24 hours).

When EZ Roll™ is installed over clay soils (CN78), water absorptions will vary depending on the depth of the base course due to the storage capacity of the soil.

As per Technical release #55, US Department of Agriculture, Soil and Conservation Service, the evaluation of storm water management objective is done by the following method: calculate the pre-construction runoff volumes and time of concentration factors, calculate area runoff volumes, calculate runoff reduction and compare to Table 1 which lists runoff percentages from various soils based on 'meadow' type cover and a 24 hour rainfall.

**Runoff % – 24 Hour Rainfall Sand to Clay Soils**

Inches	CN30	CN58	CN71	CN78
1.0	0.0	0.0	0.01	0.06
1.2	0.0	0.0	0.03	0.10
1.4	0.0	0.0	0.05	0.14
1.6	0.0	0.0	0.08	0.18
1.8	0.0	0.01	0.11	0.21
2.0	0.0	0.02	0.13	0.24
2.5	0.0	0.05	0.20	0.32
3.0	0.0	0.09	0.25	0.38
4.0	0.0	0.17	0.35	0.47
5.0	0.0	0.23	0.42	0.54
6.0	0.01	0.29	0.48	0.60
7.0	0.03	0.34	0.53	0.64
8.0	0.05	0.39	0.57	0.67
9.0	0.08	0.43	0.61	0.70
10.0	0.10	0.46	0.64	0.73
11.0	0.12	0.49	0.66	0.75
12.0	0.15	0.52	0.68	0.76

## ADA Compliancey

EZ Roll™ Gravel Pavers meet the maneuverability performance requirements of ASTM F 1951-09b. EZ Roll™ was installed and maintained according to the guidelines in this guide prior to testing.

The Americans with Disabilities Act (ADA) requires that all public areas be accessible to those with disabilities. This affects about 50 million people in this country. The Americans with Disabilities Act Accessibility Guidelines (ADAAG) specify that accessible routes must have ground and floor surfaces that are firm and stable. Surfaces that are not firm and stable limit accessibility for wheelchair, cane, crutch, walker users, parents with strollers, and other individuals with mobility limitations. Additionally, testing was conducted using a rotational penetrometer. The rotational penetrometer tests the surface for firmness and stability providing a baseline measurement that future measurements will be compared to.

**Straight Propulsion on EZ Roll™ Gravel Paver**

	Work per meter (N*m)	Trial Time (sec)
Trial 1	54.3	6.5
Trial 2	54.5	6.9
Trial 3	58.0	7.4
Trial 4	48.6	7.4
Trial 5	53.7	7.4
Average work per meter (n=3) 54.2 N*m		

**Turning on EZ Roll™ Gravel Paver**

	Work per meter (N*m)	Trial Time (sec)
Trial 1	53.3	6.5
Trial 2	50.6	6.5
Trial 3	52.9	7.1
Trial 4	50.9	7.1
Trial 5	57.6	7.2
Average work per meter (n=3) 52.4 N*m		

**Straight Propulsion on 7.1% Ramp**

	Work per meter (N*m)	Trial Time (sec)
Trial 1	75.1	6.5
Trial 2	74.3	6.4
Trial 3	74.9	6.6
Trial 4	71.1	6.6
Trial 5	74.4	6.9
Average work per meter (n=3) 74.5 N*m		

**Turning on 7.1% Ramp**

	Work per meter (N*m)	Trial Time (sec)
Trial 1	57.1	7.7
Trial 2	59.7	6.5
Trial 3	59.6	7.2
Trial 4	59.8	7.4
Trial 5	59.7	7.3
Average work per meter (n=3) 59.7 N*m		

Straight Propulsion Work Ratio 0.727

Turning Work Ratio 0.878



EZ Roll™ Gravel Pavers can be used in a number of categories that contribute points to LEED certification according to LEED v3.

## Category: Sustainable Sites

### Credit 5.1 Site Development – Protect or Restore Habitat (1 credit):

**Conserve existing natural areas and restore damaged areas to provide habitat and promote biodiversity.**

- To attain this credit, all site disturbances during construction must be limited to within a certain distance from the building perimeter. Use of EZ Roll™ Gravel Paver extends the allowed area of site disturbance from 10 ft to 25 ft, thus providing more area to work during construction.
- EZ Roll™ Gravel Paver seeded with native plants in place of asphalt or other non-pervious surfaces will contribute to the overall percentage of habitat restored.
- For projects that qualify for 5.2 (below), use of EZ Roll™ Gravel Paver on a vegetated roof with native or adapted plants can contribute to overall percentage of habitat restored or protected.

### Credit 5.2 Site Development – Maximize Open Space (1 credit):

**Provide a high ratio of open space to development footprint to promote biodiversity.**

- Application of EZ Roll™ Gravel Paver provides vegetated open space that will contribute to the open space requirements.
- Use of EZ Roll™ Gravel Paver on a vegetated roof can contribute to credit compliance.

### Credit 6.1 Stormwater Design – Quantity Control (1 credit):

**Limit disruption of natural water hydrology by reducing impervious cover, increasing on-site infiltration, reducing or eliminating pollution from stormwater runoff, and eliminating contaminants.**

- EZ Roll™ Gravel Paver can be utilized as part of a stormwater management plan as it reduces impervious cover, increases on-site infiltration, and reduces pollution from stormwater runoff.
- EZ Roll™ Gravel Paver can be used to maintain a vegetated roof, which will minimize impervious surface area onsite.

### Credit 6.2 Stormwater Design – Quality Control (1 credit):

**To limit disruption and pollution of natural water flows by managing stormwater runoff.**

- EZ Roll™ Gravel Paver can be utilized as part of a stormwater management plan as it reduces impervious cover, increases on-site infiltration, and reduces pollution from stormwater runoff.

### Credit 7.1 Heat Island Effect – Nonroof (1 credit):

**To reduce heat islands to minimize impacts on microclimates and human and wildlife habitats.**

- As open grid pavement systems, the use of EZ Roll™ Gravel Paver reduces heat absorption and contributes to the overall hardscaped area calculation for this credit.

### Credit 7.2 Heat Island Effect – Roof (1 credit):

**To reduce heat islands to minimize impacts on microclimates and human and wildlife habitats.**

- EZ Roll™ Gravel Paver utilized on a vegetated roof can reduce heat absorption.

## Category: Materials and Resources

### Credit 4.1 Recycled Content: 10% (post-consumer + ½ pre-consumer) (1 credit):

**Increase demand for the building products that incorporate recycled content materials, thereby reducing impacts resulting from extraction and processing of virgin materials.**

- EZ Roll™ Gravel Paver is made from 100% recycled HPPE (approximate blend is 50% post-consumer, 50% pre-consumer material). Utilization of this product will increase the proportion of materials used on site that are recycled, and can contribute towards attainment of this credit.

### Credit 4.2 Recycled Content: 20% (post-consumer + ½ pre-consumer) (1 credit):

**Increase demand for the building products that incorporate recycled content materials, thereby reducing impacts resulting from extraction and processing of virgin materials.**

- As cited in credit 4.1 (above), utilizing EZ Roll™ Gravel Paver can contribute to the attainment of this credit, if used in a larger proportion on site relative to the proportion of materials that are not recycled.

## Pre-Installation

1. The installation of EZ Roll™ Gravel pavers should occur after the completion of any nearby sprinkler systems or hardscape elements.
2. It is recommended to order approximately 5% additional product to the total required to offset for curves and other unforeseen variances.
3. Check with local fire authority for any inspection requirements for areas that may provide emergency vehicle access.
4. Reclaimed and back-filled areas may require compaction and testing before the base course is installed.
5. Percolation rates of underlying soil should be at least .25 inches of water per hour.
6. Water table should be at minimum 3 feet below base course.
7. Surrounding hardscape should be 1-2 inches higher than paver surface to allow for gravel to cover the top of the paver structure.
8. Define the boundary of the proposed grid using string line.

## Base Course

The first decision in project planning must address the correct base construction that will support the maximum traffic load weight anticipated on the site. **The successful installation of EZ Roll™ Gravel Pavers is directly correlated to the quality of the base foundation upon which it is installed.** To calculate the depth and composition of material for the base course consider: Load bearing capacity of subsoil, plasticity or impact of moisture, frost-heave potential, and volume of traffic.

### There are three basic options:

1. Light Load – base shall be min. 4" of engineered road base or to engineer's specification and local code.
2. Medium Load – base shall be min. 6" of engineered road base or to engineer's specification and local code.
3. Heavy Load – base shall be min. 8" of engineered road base or to engineer's specification and local code, and fire authority's requirements.

## Base course options



**NDS**<sup>®</sup>  
We put water in its place

NDS, INC.  
851 NORTH HARVARD AVE.  
LINDSAY, CA 93247  
TOLL FREE: 1-800-726-1994  
PHONE: (559) 562-9888  
FAX: (559) 562-4488  
www.ndspro.com

**EZ ROLL™ GRAVEL PAVER PRODUCT DESCRIPTION**

**CELL SIZE:** 2-1/4" HEXAGONAL CELLS  
**STOCK ROLL SIZE'S:** 3.87'W X 149'L (577 SQ. FT.)  
**NESTED HONEYCOMB CELL:** 57, 888 PSF  
**LAYOUT COMPRESSIVE STRENGTH (OPEN CELL NO FILL):** 402 PSI EXCEEDS H2O LOADING

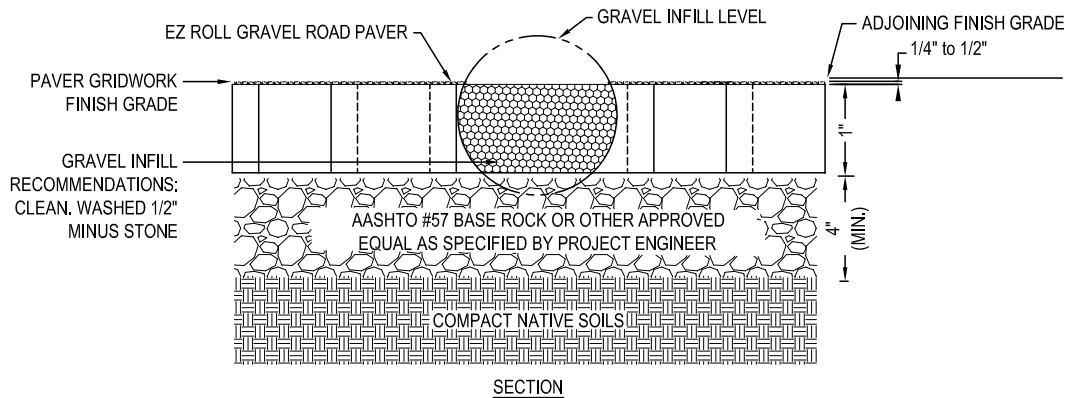
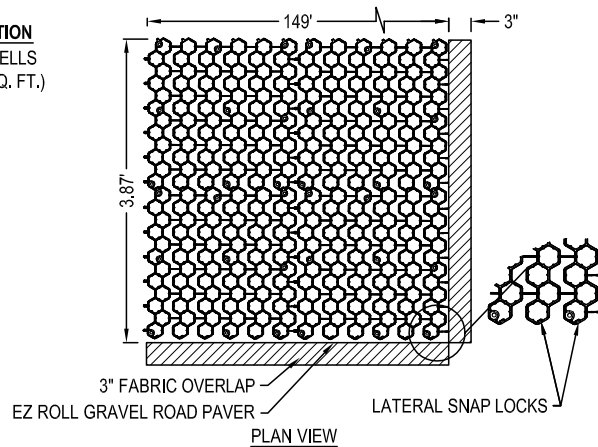

**NOTES:**

1. EXISTING SOILS SHOULD BE EVALUATED TO ENSURE PROPER STRUCTURAL AND PERMEABILITY PROPERTIES.
2. INSTALLATION TO BE COMPLETED IN ACCORDANCE WITH MANUFACTURER'S SPECIFICATIONS.
3. DO NOT SCALE DRAWING.
4. THIS DRAWING IS INTENDED FOR USE BY ARCHITECTS, ENGINEERS, CONTRACTORS, CONSULTANTS AND DESIGN PROFESSIONALS FOR PLANNING PURPOSES ONLY.
5. ALL INFORMATION CONTAINED HEREIN WAS CURRENT AT THE TIME OF DEVELOPMENT BUT MUST BE REVIEWED AND APPROVED BY THE PRODUCT MANUFACTURER TO BE CONSIDERED ACCURATE.

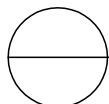

**EZ ROLL GRAVEL PAVERS**

LIGHT LOAD



REVISION DATE 8-24-2015



## Base course options (cont.):



**NDS**<sup>®</sup>  
We put water in its place

NDS, INC.  
851 NORTH HARVARD AVE.  
LINDSAY, CA 93247  
TOLL FREE: 1-800-726-1994  
PHONE: (559) 562-9888  
FAX: (559) 562-4488  
www.ndspro.com

**EZ ROLL™ GRAVEL PAVER PRODUCT DESCRIPTION**

<b>CELL SIZE</b>	2-1/4" HEXAGONAL CELLS
<b>STOCK ROLL SIZE'S</b>	3.87' X 149' (577 SQ. FT.)
<b>NESTED HONEYCOMB CELL:</b>	57,888 PSF
<b>LAYOUT COMPRESSIVE</b>	402 PSI
<b>STRENGTH (OPEN CELL NO FILL)</b>	EXCEEDS H2O LOADING

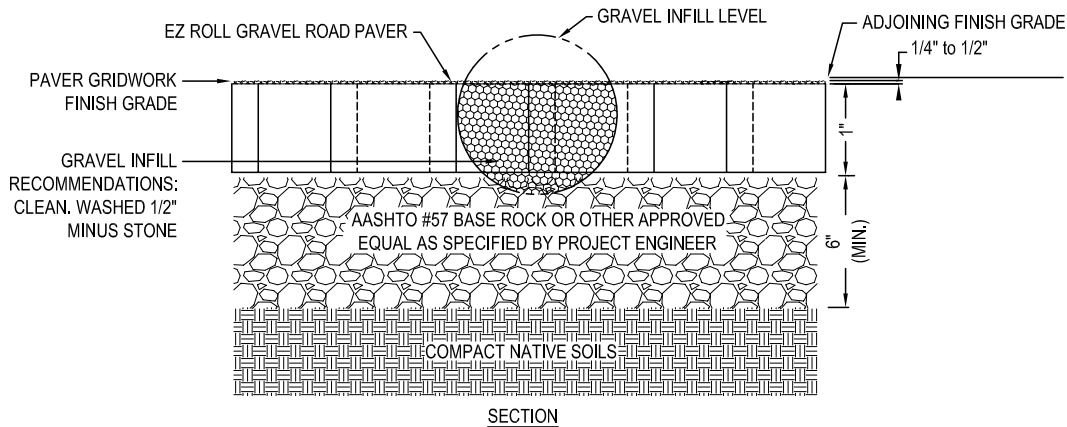
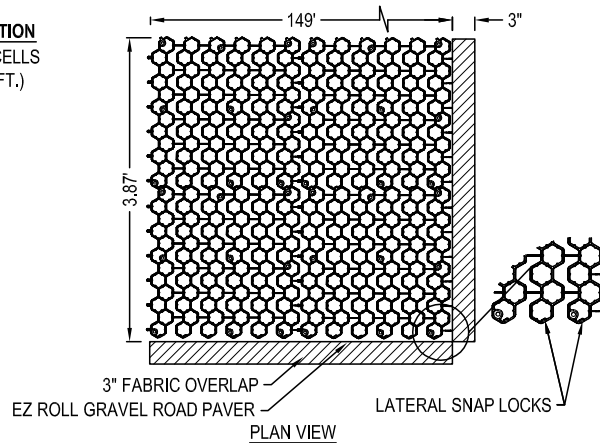

**NOTES:**

1. EXISTING SOILS SHOULD BE EVALUATED TO ENSURE PROPER STRUCTURAL AND PERMEABILITY PROPERTIES.
2. INSTALLATION TO BE COMPLETED IN ACCORDANCE WITH MANUFACTURER'S SPECIFICATIONS.
3. DO NOT SCALE DRAWING.
4. THIS DRAWING IS INTENDED FOR USE BY ARCHITECTS, ENGINEERS, CONTRACTORS, CONSULTANTS AND DESIGN PROFESSIONALS FOR PLANNING PURPOSES ONLY.
5. ALL INFORMATION CONTAINED HEREIN WAS CURRENT AT THE TIME OF DEVELOPMENT BUT MUST BE REVIEWED AND APPROVED BY THE PRODUCT MANUFACTURER TO BE CONSIDERED ACCURATE.

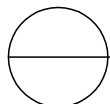

**EZ ROLL GRAVEL PAVERS**

MEDIUM LOAD



REVISION DATE 8-24-2015

## Base course options (cont.):



**NDS**<sup>®</sup>  
We put water in its place

NDS, INC.  
851 NORTH HARVARD AVE.  
LINDSAY, CA 93247  
TOLL FREE: 1-800-726-1994  
PHONE: (559) 562-9888  
FAX: (559) 562-4488  
www.ndspro.com

**EZ ROLL™ GRAVEL PAVER PRODUCT DESCRIPTION**  
**CELL SIZE:** 2-1/4" HEXAGONAL CELLS  
**STOCK ROLL SIZE'S:** 3.87' X 149' (577 SQ. FT.)  
**NESTED HONEYCOMB CELL:** 57,888 PSF  
**LAYOUT COMPRESSIVE STRENGTH (OPEN CELL NO FILL):** 402 PSI EXCEEDS H2O LOADING

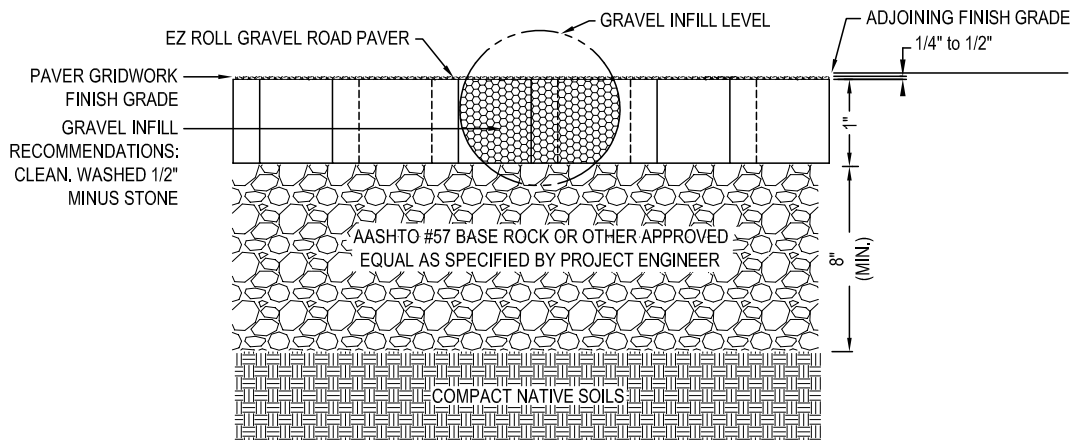
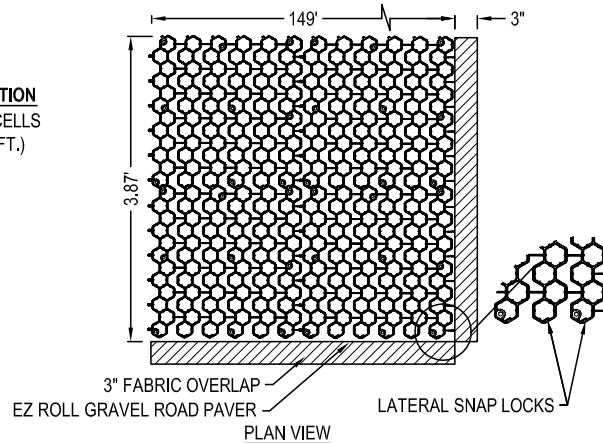

**NOTES:**

1. EXISTING SOILS SHOULD BE EVALUATED TO ENSURE PROPER STRUCTURAL AND PERMEABILITY PROPERTIES.
2. INSTALLATION TO BE COMPLETED IN ACCORDANCE WITH MANUFACTURER'S SPECIFICATIONS.
3. DO NOT SCALE DRAWING.
4. THIS DRAWING IS INTENDED FOR USE BY ARCHITECTS, ENGINEERS, CONTRACTORS, CONSULTANTS AND DESIGN PROFESSIONALS FOR PLANNING PURPOSES ONLY.
5. ALL INFORMATION CONTAINED HEREIN WAS CURRENT AT THE TIME OF DEVELOPMENT BUT MUST BE REVIEWED AND APPROVED BY THE PRODUCT MANUFACTURER TO BE CONSIDERED ACCURATE.

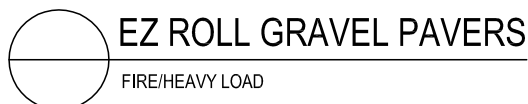

REVISION DATE 8-24-2015

## Staking Recommendations

Due to difficulty maintaining traction for motor vehicles on vegetated slopes, installing Pavers on slopes between 5-10% requires staking. Installation on slopes greater than 10% should only be used for erosion control applications.

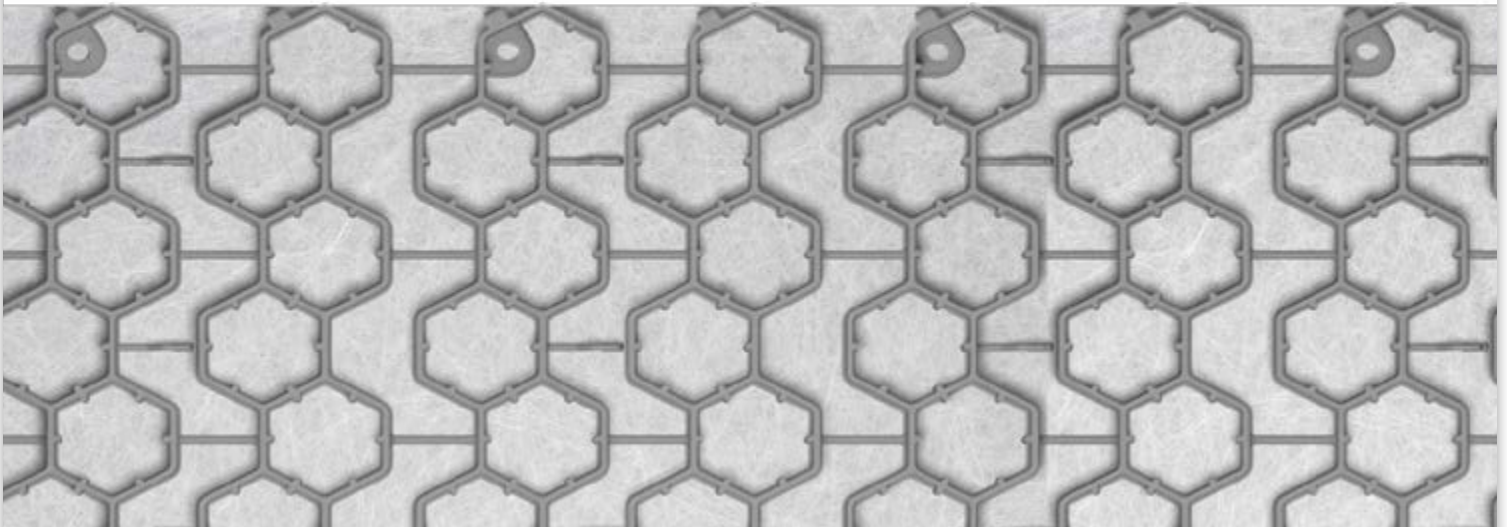



## Staking Recommendations



**NDS**<sup>®</sup>  
We put water in its place

NDS, INC.  
851 NORTH HARVARD AVE.  
LINDSAY, CA 93247  
TOLL FREE: 1-800-726-1994  
PHONE: (559) 562-9888  
FAX: (559) 562-4488  
www.ndspro.com

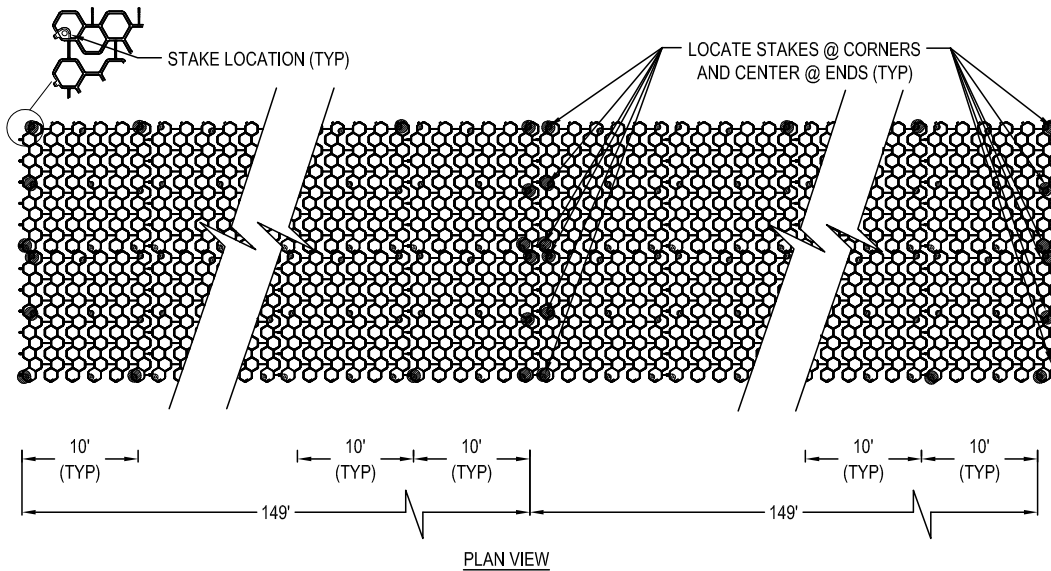

**NOTES:**

1. STAKES TO BE INSERTED IN MOLDED STAKE LOCATION AS SHOWN ABV.
2. THE DIAGRAM ABV. IS DESIGNED FOR STRAIGHT LINE RUNS. MITERS, CUTS AND DIRECTIONAL CHANGES MAY REQUIRE ADDITIONAL STAKES. CONSULT YOUR LOCAL NDS DISTRIBUTOR, NDS REPRESENTATIVE OR CONTACT NDS TECHNICAL SERVICES @ NUMBER LISTED BLW.
3. STAKES WILL BE PROVIDED BY NDS AT A QUANTITY OF 40 PER 3.87' x 149' ROLL. IF ADDITIONAL STAKES ARE REQUIRED ORDER THROUGH YOUR AUTHORIZED NDS REPRESENTATIVE USING PART # GP STAKE.
4. INSTALLATION TO BE COMPLETED IN ACCORDANCE WITH MANUFACTURER'S SPECIFICATIONS.
5. DO NOT SCALE DRAWING.
6. THIS DRAWING IS INTENDED FOR USE BY ARCHITECTS, ENGINEERS, CONTRACTORS, CONSULTANTS AND DESIGN PROFESSIONALS FOR PLANNING PURPOSES ONLY.
7. ALL INFORMATION CONTAINED HEREIN WAS CURRENT AT THE TIME OF DEVELOPMENT BUT MUST BE REVIEWED AND APPROVED BY THE PRODUCT MANUFACTURER TO BE CONSIDERED ACCURATE.

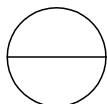

**EZ ROLL GRAVEL PAVERS**

STAKING



REVISION DATE 8-24-2015

## Markers

EZ Marker™ by NDS® is a modular solution to outline drive lanes, parking stalls, and fire lane edges for the EZ Roll™ family of permeable paver systems. After the pavers have been unrolled, pinned, and secured, EZ Marker™ snaps into the appropriate empty cells to outline whatever pattern necessary to properly direct vehicular traffic.

## Site Selection and Preparation

1. Remove all foreign top grade structures or objects, and excavate existing site soil to accommodate the base specified.
2. Install the base per architectural and/or engineering drawings and written specifications describing depth, load rating, construction materials, and required compaction.
3. Install with no more than a 6% grade for emergency access lanes or heavy vehicle access.
4. Install with no more than 10% grade when used for light vehicular traffic. Retention stakes must be installed in this application in a manner specified by a qualified architect or soils engineer.
5. Installations over 10% grades are for erosion resistance only. The installation of EZ Roll™ Gravel Pavers on any type of slope should be pinned or staked to the soil in a manner specified by a qualified architect or soils engineer.

## Paver Assembly and Installation

1. The installation of EZ Roll™ Gravel Pavers is generally done at the same time as other gravel installation on the site and after the completion major area construction.
2. Ensure that the paver is installed right-side-up with the open cells facing up. Warranties are voided for pavers installed face down.
3. Roll out the first section of pavers where there is an available straight border or where there is the longest available single run.
4. Roll out additional rolls of pavers as needed to cover large areas and securely connect the lateral snap locks to create an integral paver mat.
5. Smaller areas can be filled in by attaching single sections of pavers (detached from another roll) to the already laid out paver mat.
6. Be sure to leave the recommended 1" clearance between the paver mat and any preinstalled fixed objects or surface structures.
7. The paver can be trimmed to fit any fixed object using garden shears, a hand saw, PVC pipe cutter, utility cutter, or appropriate power saw. Be sure to follow all manufactures' operation and safety.
8. For side-to-side clips, thread the clips from one panel to the slots in the adjacent panel, apply pressure until they snap in place.
9. For end-to-end clips, push down on butterfly tabs of clip with your thumb until clip snaps into receiving slot of the next panel.
10. After assembling the paver network, re-examine all paver fittings around surface utilities and bordering structures to assure 1" clearance.
11. Fill with clean, washed gravel that is uniform in size between 3/16" and 3/8". Angular stones work best, as they do not migrate as much as rounded stones do.



## Maintenance Tips

- Do not aerate
- Utilizing skid shoes or raising the snow plow a minimum 2" above paver surface
- Do not use equipment intended for operation for thatching or scalping over the paver

## Product Guide Specification

### NDS, Inc. / April 2015

851 North Harvard Avenue Lindsay, California 93247

Toll Free: 800-726-1994

Phone: 559-562-9888

Toll Free Fax: 800-726-1998

Fax: 559-562-4488

Website: [www.ndspro.com](http://www.ndspro.com)

Email: [nds@ndspro.com](mailto:nds@ndspro.com)

Specifier Notes: This product guide specification is written in Construction Specifications Institute (CSI) 3-Part Format in accordance with *The CSI Construction Specifications Practice Guide*, including *MasterFormat*, *SectionFormat*, and *PageFormat*.

This section must be carefully reviewed and edited by the Architect to meet the requirements of the project and local building code. Coordinate this section with Division 1, other specification sections, and the Drawings. Delete all Specifier Notes after editing this section.

*Section numbers and titles are based on MasterFormat 2014 Update.*

## Section 32 12 43

### POROUS FLEXIBLE PAVING

Specifier Notes: This section covers NDS, Inc. "EZ Roll" gravel pavers to construct porous flexible paving. Consult NDS, Inc. for assistance in editing this section for the specific application.

Use of "EZ Roll" gravel pavers may contribute to LEED credits. Consult NDS, Inc. for more information.

## Part 1 General

### 1.1 SECTION INCLUDES

A. Porous flexible paving using gravel pavers.

### 1.2 RELATED REQUIREMENTS

Specifier Notes: Edit the following list of related sections as necessary. Limit the list to sections with specific information that the reader might expect to find in this section, but is specified elsewhere.

A. Section 31 20 00 – Earth Moving: Subgrade preparation.

B. Section 32 80 00 – Irrigation: Irrigation system.

C. Section 32 91 00 – Planting Preparation: Soil preparation.

Specifier Notes: Provide section number and title for method of planting gravel specified in Part 3 of this section.

D. Section 32 92 \_\_\_\_ – \_\_\_\_\_: Gravel.

E. Section 33 46 00 – Subdrainage: Subsurface drainage.



## 1.3 PRE-INSTALLATION MEETINGS

Specifier Notes: Edit pre-installation meetings as necessary. Delete if not required.

- A. Convene pre-installation meeting [1 week] [2 weeks] before start of Work of this Section.
- B. Require attendance of parties directly affecting Work of this Section, including Contractor, Architect, Installer, and Manufacturer's Representative.
- C. Review the Following:
  - 1. Materials
  - 2. Protection of in-place conditions
  - 3. Preparation
  - 4. Installation
  - 5. Adjusting
  - 6. Protection
  - 7. Coordination with other work

## 1.4 SUBMITTALS

Specifier Notes: Edit submittal requirements as necessary. Delete submittals not required.

- A. Comply with Division 1.
- B. Product Data: Submit manufacturer's product data, including preparation and installation instructions.
- C. Samples: Submit manufacturer's sample of one 24-inch by 24-inch gravel paver.
- D. Manufacturer's Certification: Submit manufacturer's certification that materials comply with specified requirements and are suitable for intended application.
- E. Sustainable Design Submittals: Submit manufacturer's sustainable design submittals for gravel pavers.
  - 1. Recycled Content: Certify percentages of post-consumer and pre-consumer recycled content.
  - 2. Regional Materials: Certify distance between manufacturer and project, in miles.
- F. Manufacturer's Project References: Submit manufacturer's list of successfully completed gravel paver projects, including project name and location, name of architect, and type and quantity of gravel pavers furnished.
- G. Installer's Project References: Submit installer's list of successfully completed gravel paver projects, including project name and location, name of architect, and type and quantity of gravel pavers installed.
- H. Warranty Documentation: Submit manufacturer's standard warranty.

## 1.5 QUALITY ASSURANCE

- A. Manufacturer's Qualifications: Manufacturer regularly engaged, for a minimum of 10 years, in the manufacturing of gravel pavers of similar type to that specified.
- B. Installer's Qualifications:
  - 1. Installer regularly engaged, for a minimum of 5 years, in installation of gravel pavers of similar type to that specified.
  - 2. Employ persons trained for installation of gravel pavers.

## 1.6 DELIVERY, STORAGE, AND HANDLING

- A. Delivery Requirements: Deliver gravel pavers to site in manufacturer's original, unopened containers and packaging, with labels clearly identifying product name and manufacturer.
- B. Storage and Handling Requirements:
  - 1. Store and handle gravel pavers in accordance with manufacturer's instructions.
  - 2. Keep gravel pavers in manufacturer's original, unopened containers and packaging until installation.
  - 3. Store gravel pavers in clean areas, protected from exposure to harmful weather conditions.
  - 4. Store gravel pavers out of direct sunlight.
  - 5. Protect gravel pavers during storage, handling, and installation to prevent damage.

## 1.7 AMBIENT CONDITIONS

- A. During Cold Weather:
  - 1. Do not use frozen materials.
  - 2. Do not use materials mixed or coated with ice or frost.
  - 3. Do not build on frozen work.
- B. During Wet Weather: Do not build on wet, saturated, or muddy subgrade.

## Part 2 Products

### 2.1 MANUFACTURERS

- A. Manufacturer: NDS, Inc., 851 North Harvard Avenue, Lindsay, California 93247. Toll Free 800-726-1994. Phone 559-562-9888. Toll Free Fax 800-726-1998. Fax 559-562-4488. Website [www.ndspro.com](http://www.ndspro.com). Email [nds@ndspro.com](mailto:nds@ndspro.com).

Specifier Notes: Specify if substitutions will be permitted.

- B. Substitutions: [Not permitted] [Comply with Division 1].

### 2.2 MATERIALS

- A. Gravel Pavers: NDS "EZ Roll" Gravel pavers, model "EZ4X150".
  - 1. Injection-molded, nested-honeycomb, rolled-plastic-panel gravel pavers for permeable, natural-gravel paved environments.
  - 2. Load-transfer paving system.
  - 3. Use full rigid base course to prevent pavers from being pressed into subbase.
  - 4. Material: 100 percent recycled polyolefin plastic with carbon black for UV stabilization.
  - 5. Recyclable Content: 100 percent.
  - 6. Paver Size: Preassembled rolls comprised of 24-inch by 24-inch panels by 1 inch high with integrated connecting cross links.
  - 7. Wall Thickness: 0.12 inch.
  - 8. Cells:
    - a. Number per Paver: 72.
    - b. Shape: Hexagon.
    - c. Size: 2-1/4-inches.
    - d. Form: Nested honeycomb.
  - 9. Bottom Surface of Pavers: Flat, without vertical posts or obstructions.
  - 10. Top Surface of Pavers: Smooth, without notches or grooves.
  - 11. Connections:
    - a. Connecting Clips per Paver: 24.
    - b. Between Panels to Form Rolls: End-to-end clips snap-lock together.
    - c. Between Rolls: Side-to-side clips snap-lock together.
    - d. Does not require additional parts or tools.
  - 12. Bottom Open Area: Greater than 80 percent.
    - a. Total Bottom Open Area per Paver: 478 square inches.
  - 13. Paver Color: Black.
  - 14. Paver Compressive Strength, Empty Cells: 57,888 psf.
  - 15. Nominal Coverage Area per Paver: 4 square feet.
  - 16. Weight per Paver: 2.31 pounds.
  - 17. Chemical Resistance: Superior chemical resistance; totally inert.

## 2.2 MATERIALS (CONT.)

Specifier Notes: Edit the following for the local available base course material and anticipated traffic loads. Consult NDS, Inc. for more information.

B. Base Course: Sandy gravel material from local sources, commonly used for road base construction, passing the following sieve analysis:

Percent Passing	Sieve Size
100	3/4 inch
85	3/8 inch
60	#4
30	#40
< 3	#200

1. Sources of the material may include pit run or crusher run.
2. Crusher run material will typically require sand be added (33 percent by volume) to ensure long-term porosity.
3. Should local sources not be available, alternative mixture can be created by mixing 2/3 crushed stone (0.75-inch diameter) with 1/3 sand, as available.
4. Alternative materials, such as washed or clean stone (0.75-inch diameter typical) may be used with soil separator above stone base and below growing medium.
5. Confirm base course sieve analysis by testing material.

Specifier Notes: The selection of sandy loam or loam soil should be made based on the soil requirements of the gravel variety selected for the project.

C. Soil:

1. Sandy loam or loam soil.
2. Sand: Not acceptable.

Specifier Notes: Select a gravel variety well suited to the anticipated traffic frequency and local heat and growing conditions.

D. Gravel: Specified in Section 32 92 \_\_\_\_\_.

## Part 3 Execution

### 3.1 EXAMINATION

- A. Examine areas to receive porous flexible paving.
- B. Examine subgrade and base course installed conditions.
- C. Check for improperly compacted trenches, debris, and improper gradients.
- D. Notify Architect of conditions that would adversely affect installation or subsequent use.
- E. Do not begin preparation or installation until unacceptable conditions are corrected.

## 3.2 PREPARATION

- A. Protection of In-Place Conditions: Protect adjacent areas and landscaping from installation of porous flexible paving.
- B. Place base course material over prepared subbase to grades indicated on the Drawings, in lifts not to exceed 6 inches.
- C. Compact each lift separately to minimum 95 percent Modified Proctor.
- D. Leave minimum 1-1/2 inches for gravel pavers and soil.
- E. Fill to final grade.

## 3.3 INSTALLATION

- A. Install gravel pavers in accordance with manufacturer's instructions at locations indicated on the Drawings.
- B. Install Gravel pavers by placing units with cells facing up and connecting lateral snap locks together to maintain proper spacing and to interlock units.
- C. Clearance: Leave 1-inch-minimum clearance between gravel pavers and fixed objects or surface structures.
- D. Anchor gravel pavers placed on curves and slopes to base course as required to secure pavers in place.
- E. Top of Cells: Leave top of cells 1/4 inch to 1/2 inch below surface of adjacent hard-surface pavements.
- F. Install soil in cells and between cells as gravel pavers are laid in sections.
- G. Add soil to gravel pavers from an area already filled with soil.
- H. Spread soil to fill gravel pavers to top surface.

Specifier Notes: Specify one of following methods of planting gravel: top dressing with sod, recessed sod planting, seeding, or hydroseeding. Include the section number for the section specifying the appropriate method of planting.

- I. Planting: Plant gravel by [top dressing with sod] [recessed sod planting] [seeding] [hydroseeding] as specified in Section 32 92 \_\_\_\_.
- J. Fill gravel pavers with soil and plant within 30 days of being installed.

## 3.4 ADJUSTING

- A. Remove and replace with new materials, segments of gravel pavers where 3 or more adjacent cells are broken or damaged.

## 3.5 PROTECTION

- A. Protect Work of this Section:
  - 1. From traffic until gravel is sufficiently established to handle traffic.
  - 2. From damage or deterioration during construction.





## SUSTAINABLE STORMWATER SOLUTIONS

NDS has an over 40-year history manufacturing quality stormwater management products. In that time our understanding and appreciation for the effects of stormwater runoff on our environment has evolved, culminating in the development of S5 Sustainable Stormwater Solutions. This evolution towards a system-based approach to comprehensive stormwater management represents a paradigm shift reflective of ongoing research, changing attitudes and advancing regulations that aim to reduce runoff and maximize groundwater recharge. NDS is committed to providing effective solutions for the next 40 years and beyond.

